

GJGOT

GAOJIA OPTOELECTRONIC TECHNOLOGY CO., LTD | 高佳光电科技有限公司



致力于成为全球最优秀的一站式光学元件供应商
TO BE THE BEST OPTICAL COMPONENT SUPPLIER IN THE WORLD

致力于成为全球最优秀的一站式光学元件供应商
TO BE THE BEST OPTICAL COMPONENT SUPPLIER IN THE WORLD

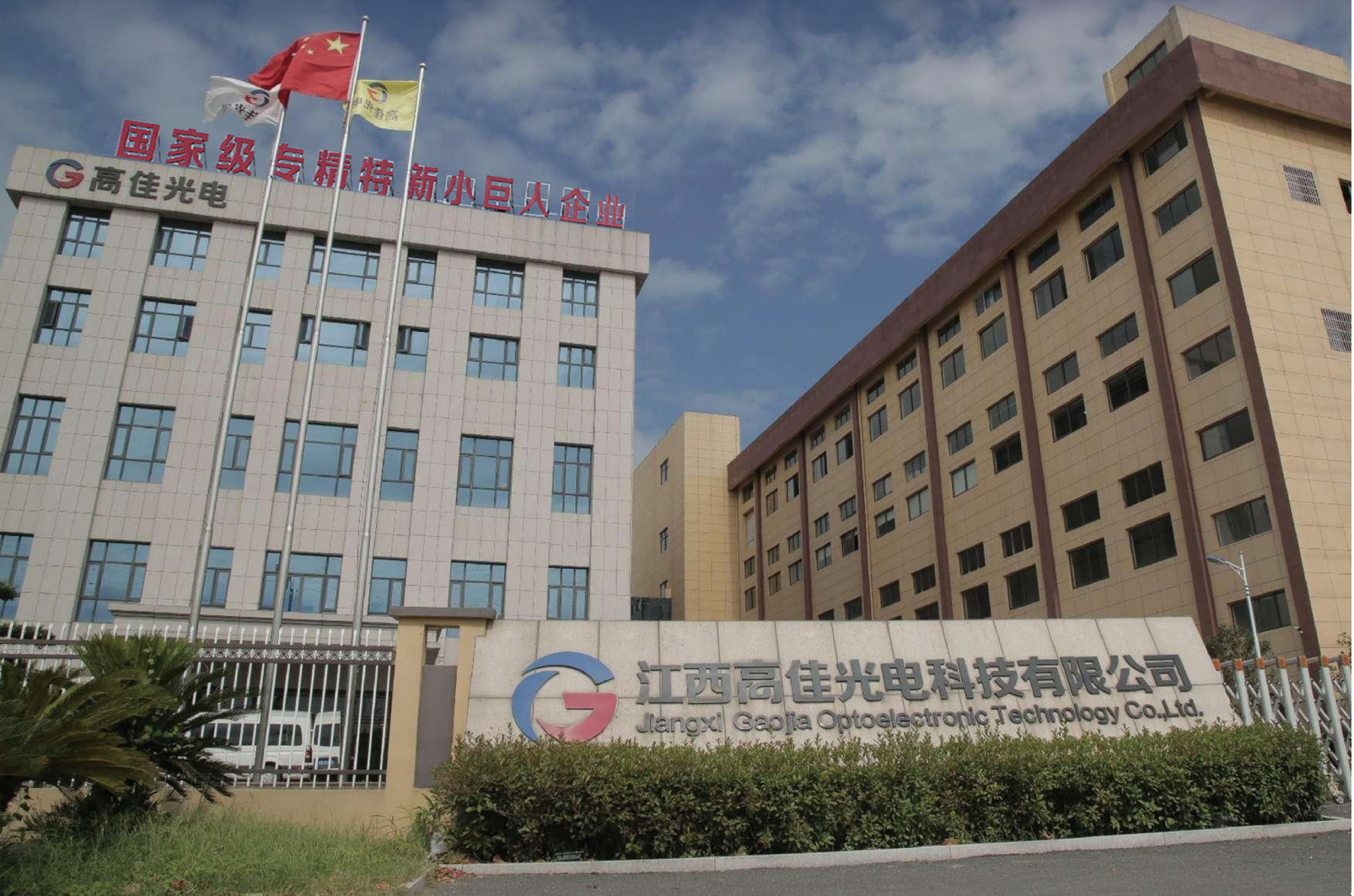



目录

CONTENTS

一	公司简介 Company Profile	04
二	发展历程 Development History	06
三	产品系列 Product Series	08
四	生产流程 Production Process	12
五	荣誉证书 Certifications & Honors	14
六	客户网络 Customer Network	16





江西高佳光电科技有限公司

JIANGXI GAOJIA OPTOELECTRONIC TECHNOLOGY CO., LTD

江西高佳光电科技有限公司成立于 2010 年 4 月，致力于成为全球最优秀的一站式光学元器件供应商，是一家以光学球面元器件、棱镜、平面元器件、树脂非球面元器件、精密模压非球面元器件、光学镜头等系列产品的国家级“专精特新”高新技术企业。2020 年，公司对越南制造工厂的投资标志着高佳向“双基地”生产模式的战略扩张，进一步巩固了公司在中国和越南两地的运营布局。

Jiangxi Gaojia Optoelectronic Technology Co., Ltd. is committed to become the most excellent optical component supplier in the world since it was founded in April 2010. It is A National-level "SRDI" (Specialized, Refined, Distinctive, and Innovative) High-tech Enterprise with optical spherical components, prism, plane lens, plastic aspheric components, precision moulded aspheric components, optical lenses and other series products. In 2020, the company's investment in a Vietnamese manufacturing plant marked a strategic expansion into a dual-base production model, solidifying its operational footprint across both China and Vietnam.





江西高佳和高佳（越南）两地总投资 6.5 亿元，全球雇员近 3000 多人。公司总部位于中国最大的光学生产基地：江西省上饶市中国光学城。目前已形成年产光学元器件 4 亿片，光学镜头 3500 万支，模造非球面元器件 3000 万片，棱镜平面元器件 3000 万片的产能。并先后通过 ISO9001、IATF16949 质量管理体系认证、ISO45001 职业健康管理体系认证及 ISO14001 环境管理体系认证。

Scale & Certified Quality You Can Trust

With a massive annual capacity—including 400 million optical components and 20 million lens assemblies—we are ready to support your most demanding projects at scale.

Our operations are fully certified, ensuring global standards of quality, safety, and environmental responsibility.

ISO 9001 (Quality)

IATF 16949 (Automotive Quality)

ISO 14001 (Environment)

ISO 45001 (Health & Safety)

发展历程

Development History

2025

越南新基地投入
杭州研发中心成立
Set up NGHE AN Vietnam Gao Jia Company
Set up the Hangzhou R&D Center

2022

获得 IATF16949 体系证书
Successfully achieved IATF 16949 certification



2010

球面元件工厂成立
Set up Spherical components factory

2012

通过 ISO9001 认证
Certified to the ISO 9001 International
Standard

2020

成立高佳（越南）公司
Set up VINH PHUC Vietnam Gao Jia Company

2018

成立精密模压非球面事业部
Launched a new Precision Molded
Aspherical Lens Division.

2017

江西光学基地新工厂投产
New Plant Operations at
Jiangxi Optical Base

2016

成立注塑非球面事业部
进入超精密制造领域
Established the injection-molded aspherical lenses department,
entering the field of ultra-precision manufacturing

2013

成立镜头组装部
Set up the lens assembly department

安防领域视觉镜头 Security Surveillance Lenses



安防监控镜头是视频监控系统的成像核心，在智慧城市、智能交通等领域扮演着关键角色。它采用包含非球面镜片的复杂光学设计与多层增透膜技术，以实现高分辨率、低畸变与精准的色彩还原。凭借其坚固的结构与防护性镀膜，镜头足以应对全天候的严苛挑战。最终，镜头输出的高质量视觉数据为后端 AI 算法的精确分析提供了坚实基础，是现代安防系统不可或缺的光学解决方案。

As the imaging core of video surveillance systems, security lenses are critical components in applications like smart cities and intelligent transportation. They feature advanced optical designs with aspherical elements and multi-layer coatings to deliver high-resolution, low-distortion imagery with faithful color reproduction. Engineered for durability, their rugged construction and protective coatings ensure reliable performance in the most demanding all-weather conditions. Ultimately, the pristine visual data captured by these lenses provides the essential groundwork for precise AI-driven analytics, making them an indispensable optical solution for any modern security infrastructure.



应用范围

Application Range

安防监控
Security surveillance

智能家居
Smart Home

工业巡检
Industrial Inspection

测温系统
Temperature Measurement System

物联网
Internet of Things (IoT)

城市设施
Urban facilities



加工能力

Process Capability

焦距 FL	光圈 F	像面尺寸IPS	机械后焦FL	接口 IF	像素对应 PX	视角Sensor	角度 H-Fov	视角Sensor	角度 D-Fov
2.8mm	F1.0/F1.6 F1.2/ F2.0	1/2.7"	4.18mm	M12*P0.5	8MP/5MP/HD	1/2.7"(H)	109.7°	1/2.7"(D)	131.0°
4mm	F1.0/F1.6 F1.2/ F2.0	1/2.7"	3.86mm	M12*P0.5	8MP/5MP/HD	1/2.7"(H)	88.1°	1/2.7"(D)	104.1°
6mm	F1.0/F1.6 F1.2/ F2.0	1/2.7"	4.76mm	M12*P0.5	8MP/5MP/HD	1/2.7"(H)	56.6°	1/2.7"(D)	65.5°
2.8mm	F1.0	1/1.8"	4.0mm	M16*P0.5	8MP/4MP	1/1.8"-8MP(H)	109.8°	1/1.8"-8MP(D)	130.9°
4mm	F1.0	1/1.8"	3.91mm	M16*P0.5	8MP/4MP	1/1.8"(H)	93.1°	1/1.8"(D)	110.8°
6mm	F1.0	1/1.8"	3.84mm	M16*P0.5	8MP/4MP	1/1.8"(H)	57.1°	1/1.8"(D)	66.3°
8mm	F1.0	1/1.8"	4.0mm	M16*P0.5	8MP/4MP	-	-	-	-
2.8mm	F1.0	1/1.8"	4.5mm	M16*P0.5	8MP/4MP	1/1.8"	109.4°	1/1.8"	131.8°
4mm	F1.0	1/1.8"	4.52mm	M16*P0.5	8MP/4MP	1/1.8"(H)	93.1°	1/1.8"(D)	111.8°
2.8mm	F1.0	1/1.8"	4mm	M16*P0.5	8MP/4MP	1/1.8"(H)	109.0°	1/1.8"(D)	131.6°
4mm	F1.0	1/1.8"	4.0mm	M16*P0.5	8MP/4MP	-	-	-	-
2.3mm	F2.2	1/2.8"	3.2mm	M8*P0.35	5MP/HD	1/2.8"(H)	139.1°	1/2.8"(D)	170.9°
2.1mm	F2.0	1/2.8"	3.37mm	M12*P0.5	5MP/3MP	1/2.8"(H)	144.0°	1/2.8"(D)	166.3°
2.4mm	F1.6	1/2.8"	3.05mm	M8*P0.35	8MP/5MP/3MP	1/2.8"(H)	140.5°	1/2.8"(D)	170.2°
2.26mm	F1.6	1/2.7"	3.11mm	M12*P0.5	5MP/HD	1/2.7"(H)	140.9°	1/2.7"(D)	169.7°
2.8mm	F2.2	1/2.8"	3.33mm	M12*P0.5	HD/MP	1/2.8"(H)	117.8°	1/2.8"(D)	141.9°
2.6mm	F2.0	1/2.7"	4.17mm	M12*P0.5	5MP/HD	1/2.7"(H)	135.1°	1/2.7"(D)	160.0°

成像类透镜

Imaging Lens



高佳是精密光学制造领域的卓越专家，我们擅长高精制造，满足汽车光学最严苛的光学元件需求。已验证的核心能力包括：擅长加工中小口径透镜、小 R 值镜片，双台阶 R 值目前可达到 1.25mm，目前 R 值可到达 0.68mm 并可量产。擅长加工胶合切割镜片，AR 产品胶合件切割，破口要求：0.1mm 以内。擅长加工手机棱镜镜片，面精度： $PV \leq \lambda/10$, ($N \leq 0.2$)，外观：符合 MIL-PRF-13830B 标准且达到 MIL10-5，粗糙度： $Ra \leq 0.3nm$ 。

As a specialist in precision optics, Gaojia provides high-precision manufacturing solutions for the most demanding automotive applications. Our key capabilities include processing small-to-medium diameter lenses and lenses with a short radius of curvature (small R-value lenses). We achieve a dual-step R of 1.25 mm and a standard single R down to 0.68 mm.

Bonded & Diced Assemblies: High-precision machining of bonded and AR-coated stacks, with edge chipping controlled to ≤ 0.1 mm.

Smartphone Prism Lenses: Delivering exceptional quality:

Surface Form: $PV \leq \lambda/10$ ($N \leq 0.2$)

Surface Quality: 10-5 per MIL-PRF-13830B

Surface Roughness: $Ra \leq 0.3$ nm

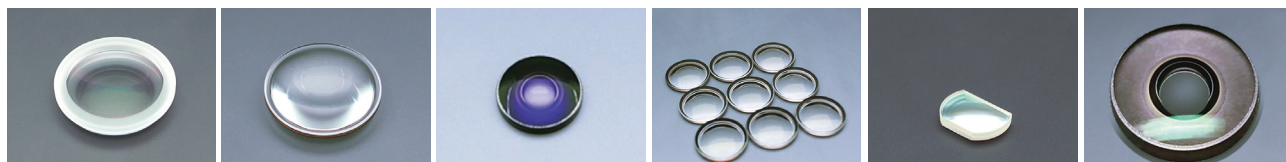

加工能力

Process Capability

项目 (Item)	直径 2-5 mm	直径 6-10 mm	直径 10-20 mm	直径 20-30 mm
PV	0.5 μm	0.8 μm	1.0 μm	1.2 μm
Bestfit PV	0.2 μm	0.3 μm	0.3 μm	0.5 μm
中心厚度公差 Center Thickness Tol	$\pm 3 \mu m$	$\pm 5 \mu m$	$\pm 10 \mu m$	$\pm 15 \mu m$
外径公差 Outer Diameter Tol	$\pm 3-5 \mu m$	$\pm 5 \mu m$	$\pm 5-10 \mu m$	$\pm 10 \mu m$
S1~S2 面间偏心 Eccentricity (S1~S2)	3 μm	3-5 μm	5 μm	8 μm
单面偏心 Single-Surface Eccentricity	2 μm	3-5 μm	5 μm	5 μm
外观等级 Appearance Grade	20/10 (40/20)	40/20 (60/40)	40/20 (60/40)	60/40 (80/50)
产能 (每月) Monthly Capacity	1.2KK	0.9KK	0.6KK	0.4KK

镀膜加工能力

Coating Processing Capability

全行业唯一三腔体镀膜机
The Industry's Only Triple-Chamber Coating Machine

公司已购入 6 台连续式溅射镀膜机。配有 Holder 翻转机构、伸缩挡模板等特殊机构，可实现车载镜头 G1 镜片，加硬防水膜、凹面鬼影消除专用增透膜，三个面镀膜一次完成加工。实现高效大批量连续性溅射镀膜生产。颠覆业内现有生产模式，是行业内镀膜量产效率的三倍，达到全球领先水平。

G1 Lens Breakthrough: Triple-Surface Coating in One Step

Our new, custom-engineered in-line sputtering systems feature in-situ substrate flipping and retractable masks. This enables a revolutionary single-process workflow to apply three functional coatings to three surfaces of G1 automotive lenses in one continuous run:

Hardened hydrophobic coating

Ghost-suppressing AR coating for concave surfaces

The result is a 3x higher production throughput than industry standards, setting a new global benchmark for efficiency.

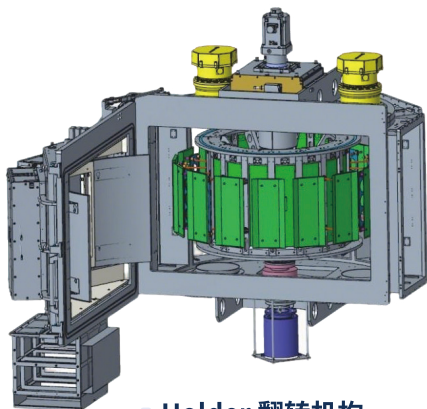

● Holder 翻转机构

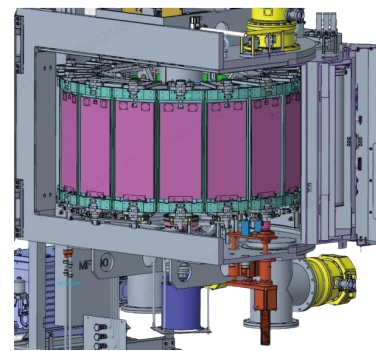

● 伸缩挡模板

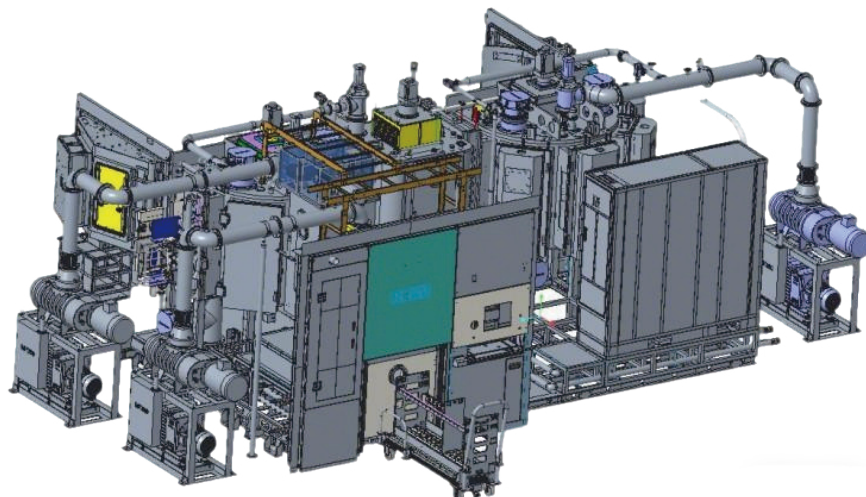

精密模压非球面产品

Precision Molded Aspherical Products

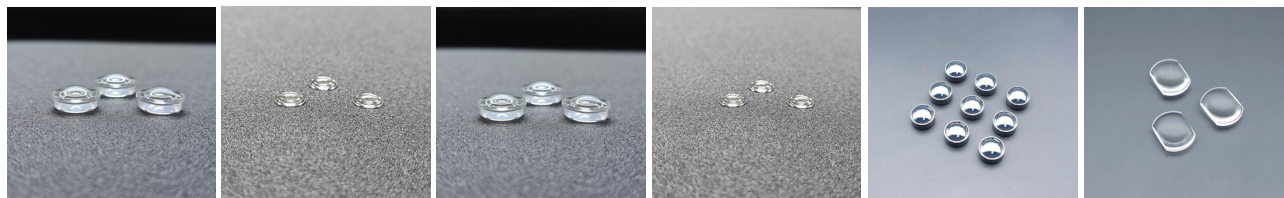

玻璃非球面镜片通过引入非线性表面轮廓，突破了传统球面光学的物理限制。它不仅解决了球差和畸变的难题，还利用玻璃材料本身的稳定性，实现了在极端环境下依然保持高分辨率成像的能力。相比传统球面镜片，玻璃非球面镜片的优势是：有效校正像差、减少镜片数量，能满足产品小型化、轻量化和高清化的严苛要求。

By incorporating a non-linear surface profile, glass aspherical lenses overcome the physical limitations of traditional spherical optics. They not only correct for challenging aberrations like spherical aberration and distortion, but also leverage the inherent stability of glass to maintain high-resolution imaging even in extreme environments. Compared to conventional spherical lenses, the advantages of glass aspheres are clear: they provide superior aberration correction and reduce the required number of lens elements, thereby meeting the stringent demands for miniaturization, lightweight design, and high-definition performance.

加工能力

Process Capability

项目 (Item)	2-7(mm)	7-15(mm)	15-24(mm)	24-35(m)	备注 (remark)
PV	0.6um	0.6um	1um	1.2um	需非球面边缘切线角度 Tangent angle of asphericege is key factor
Bestfit PV	0.2um	0.2um	0.4um	0.6um	
AS	0.15um	0.15um	0.3um	0.5um	
中心厚度公差 (Center thickness tolerance)	±3um	±3um	±10um	±15um	
非球面矢高公差 (Sag tolerance)	±10um			±10um	
外径公差 (Outer diameter tolerance)	常规 ±3-5um	±5um	±5-10um	±10um	需考虑外径加工工艺 Outsidediameter processing technology is key factor
	切边	高精度 ±0.03、中精度 ±0.05、低精度 ±0.1 (High precision ±0.03、medium precision ±0.05、low precision ±0.1)			
倾斜 (Tilt)	高精度 60'、中精度 90'、低精度 120' (High precision 60'、medium precision 90'、low precision 120')				
S1-S2 面间偏心 (S1-S2 Deceter)	3um	3-5um	3-5um	10um	
外观等级 (Appearance level)	40/20(60/40)	40/20(60/40)	40/20(60/40)	80/50(60/40)	需考虑材料不同 Material is key factor

注塑成型非球面产品

Injection-molded Aspherical Products

组立配有注塑成型机 50 台，配有七条全自动组装线和五条半自动组装线，月可出 5M/2M 玻璃镜头 300 万台；全玻镜头 30 万台的能力，实现了月产 700 万 PCS 镜片和月产 300 万只镜筒底座的能力，此事业部擅长制作 OEM 镜头，配套齐全，检测完善，成本有优势。

Gaojia's Lens Assembly Division operates 50 injection molding machines and 12 automated/semi-automated assembly lines. Our monthly capacity reaches 3 million hybrid glass-plastic lenses (5MP/2MP) and 300,000 all-glass lenses. Supporting this, we internally produce 7 million lens elements and 3 million lens housings per month.

We excel as an OEM partner, providing a competitive edge through our end-to-end manufacturing, complete inspection processes, and cost-effective solutions.

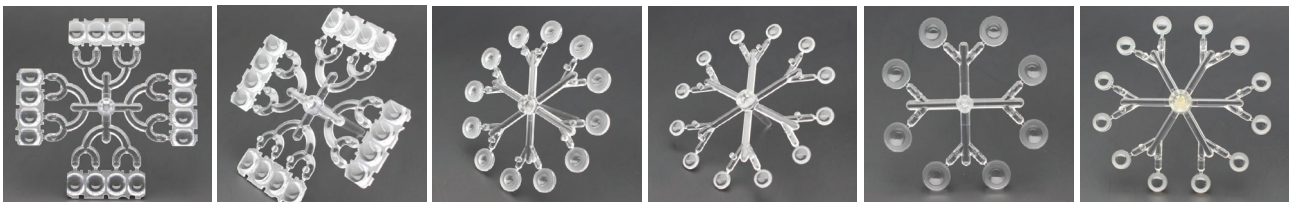

产品参数

Product Specifications

项目 (Item)	Φ3-Φ10(mm)	Φ10-Φ20(mm)
Design-R_PV	0.4μm-0.7μm	0.7μm-1.5μm
直径公差 (Diameter Tolerance)	±0.003mm	±0.005mm
中心厚度公差 (Centre thickness tolerance)	±0.003mm	±0.005mm
面间偏心 (Inter-Surface Decentration)	1.5-2.5μm	3μm-5μm
表面粗糙度 (Surface roughness)	3nm	5nm-7nm
外观质量 (Appearance quality)	40-20	

荣誉资质

Honorary Qualifications

高新技术企业

High-Tech Enterprise



国家高新技术企业
National High-Tech Enterprise



高新技术企业证书
High-Tech Enterprise Certification



IATF-16949



ISO14001: 2015



ISO-45001: 2018



ISO-9001: 2015



有效数据 可视化分析 精准决策
EFFECTIVE DATA VISUALIZATION ANALYSIS AND ACCURATE DECISION-MAKING

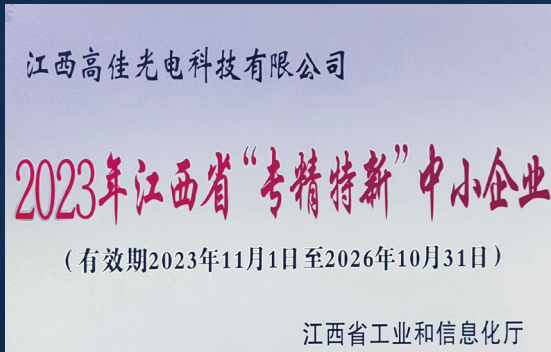

江西省专精特新企业
Jiangxi 'Specialized & Innovative' Enterprises

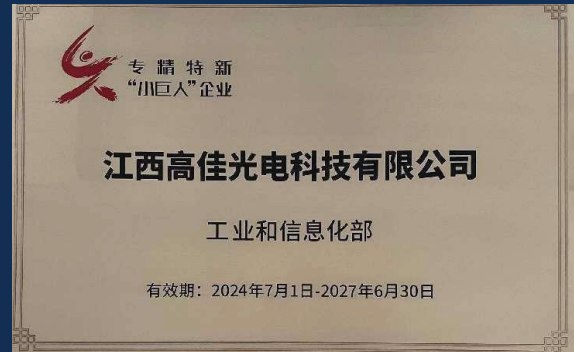

国家级专精特新小巨人企业
National 'Little Giant' Enterprise



• ISO 9001: 2015



• ISO 14001: 2015



• IATF 16949: 2016



客户网络

Customer Network

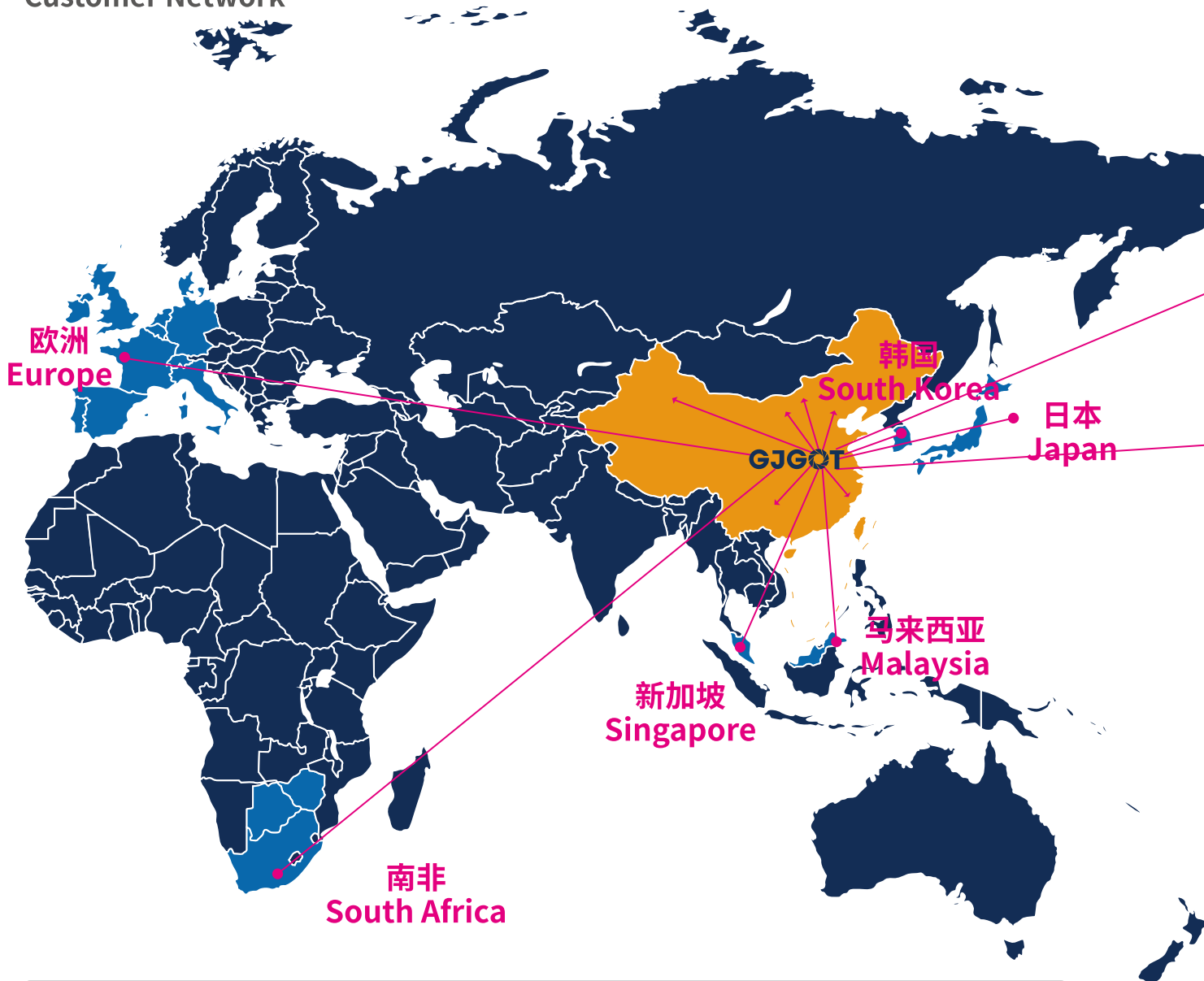

优质的服务与强大的专业能力使高佳的客户遍及全球，产品远销美国、日本、欧洲等经济发达国家和地区。良好的口碑使高佳成为国内外享有盛誉的专业光学元器件供应商。

Excellent service and strong professional expertise have enabled Gaojia to serve customers worldwide, with products exported to economically developed countries and regions such as the United States, Japan, and Europe. Its outstanding reputation has made Gaojia a highly respected professional supplier of optical components both domestically and internationally.

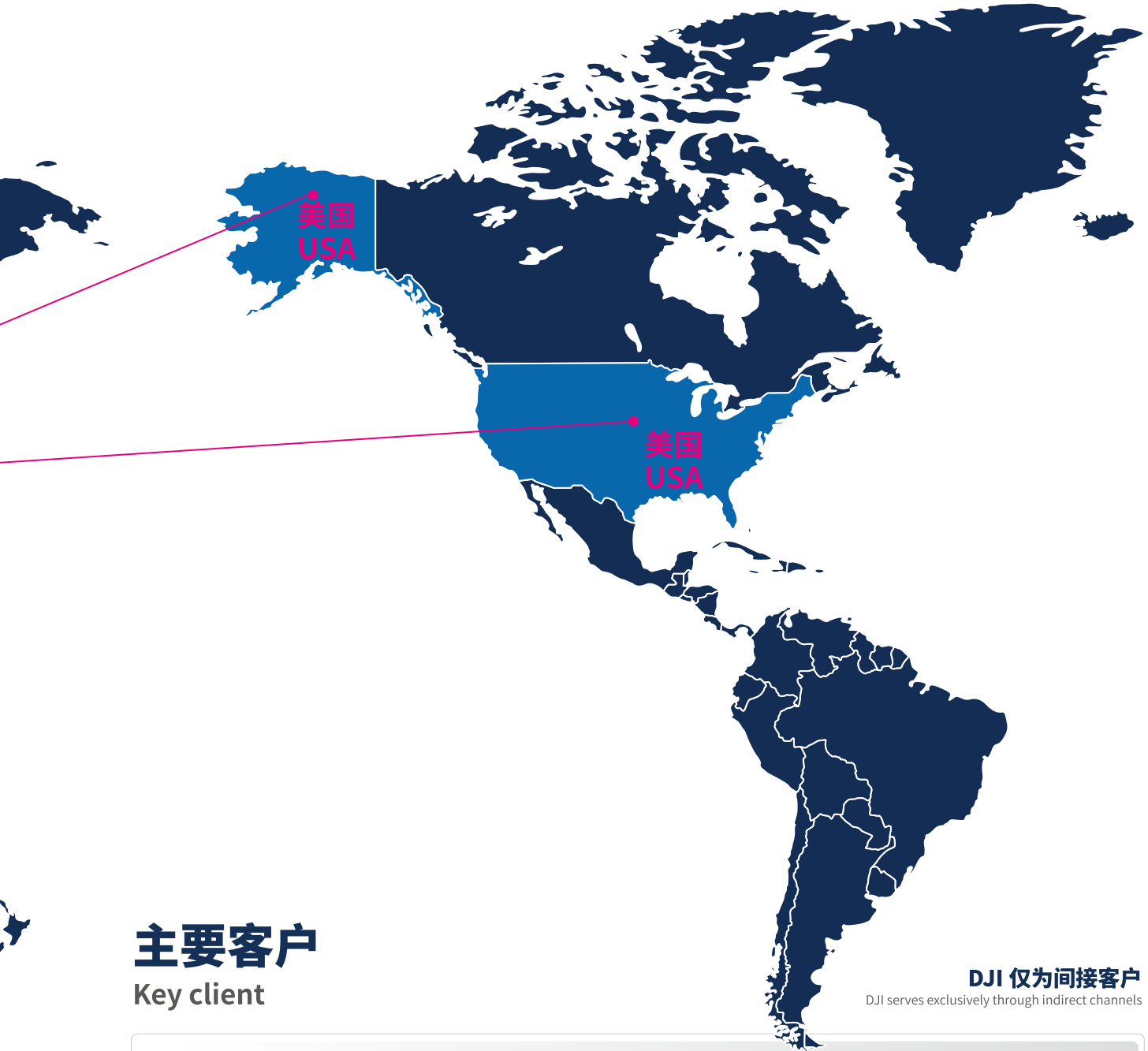

主要客户

Key client

DJI 仅为间接客户
DJI serves exclusively through indirect channels



• 舜宇车载



• 大疆



• 中电海康



• 三星



• 萤石



• 大立光



• 比亚迪

光学球面元器件加工

Spherical Optical Component Manufacturing

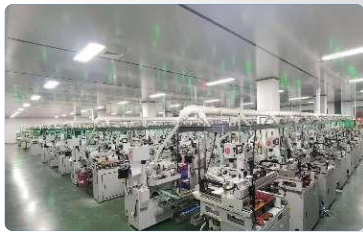

芯取
Centering

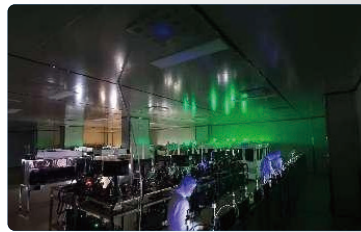

胶合
Lens gluing



镀膜
Coating

球面制造自动化

Automation in Spherical Optics Fabrication



检测自动化
Inspection automation



精磨自动化
Precision grinding automation

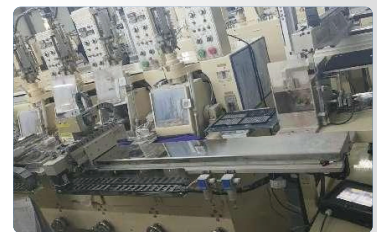

研磨自动化
Polishing automation

品质保证

Quality Assurance



DLC 镀膜机
Mould Coating Machine

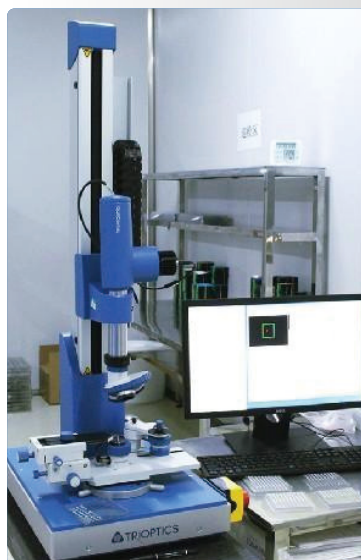

全欧偏心仪
TRIOPTICS OptiCentric



蔡司三坐标测量机
ZEISS PRISMO



松下 UA3P
Panasonic UA3P





微信扫码 关注我们
Scan the QR Code to Follow Us



江西省上饶市经济技术开发区兴业大道 7 号
No. 7, Xingye Avenue, Shangrao Economic and Technological Development Zone,
Jiangxi Province, China

越南义安省荣市伟华工业区一区 B-2-4
B-2-4, Zone 1, Weihua Industrial Park, Vinh City, Nghe An Province, Vietnam



+86-13970379135	+84-0888129898
+86-13767334852	+84-0888118803
+86-13970374790	+84-0888181055
+86-13767379261	



xbg@gaojiaoptotech.com
gjot@gaojiaoptotech.com
xhz@gaojiaoptotech.com



www.gaojiaoptotech.com